

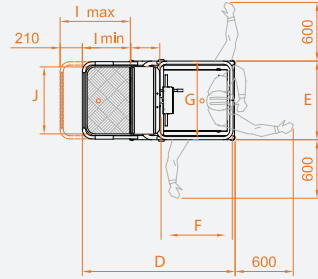

level
IŞ MAKİNELERİ

0850 969 59 79

Odunluk Mah. Lefkoşe Cad. Mıhraplı Plaza B Blok. No:9/3 Nilüfer - BURSA
www.levelmakine.com / level@levelmakine.com

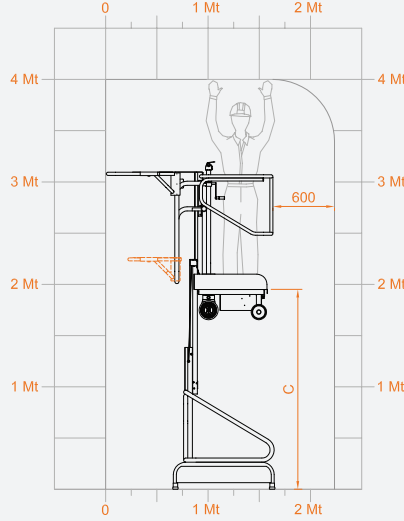
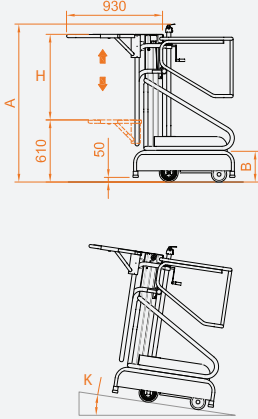

SPECIFICATIONS

ÖZELLİK

40MOVEPICKING

SPECIFICATIONS	ÖZELLİK	40MOVEPICKING
Max capacity	Kaldırma kapasitesi	110+40 kg.
Number of people	Çalışacak kişi sayısı	1
Use	Kullanım yeri	Internal-External
A Stoved height	Yükseklik - kapalı	1550 mm
B Min. height from the ground to the platform level		310 mm
C Max.height from the ground to the platform level		1960 mm
D/E/F Overall machine dimensions	D/E/F Toplam makine boyutları	995 x 1640 x 740 mm
G/H Cage inner dimensions	G/H Sepet iç ölçüleri	700 x 680 mm
Machine weight	Makine ağırlığı	172 kg.
N° 2 batteries AGM 12V		33 Ah*-45 Ah **
Picking Platform	Toplayıcı Platform	450 mm x 660 mm
Storage tray		270 mm x 660 mm
Picking plate capacity		40 kg.
Driving steering-whells dimensions		Ø190 x 60
Fixed whells dimensions		Ø150 x 45
Turning radius		800
Max.rising speed	Maksimum yükselme hızı	0,08 m/s
Max.descending speed	Maksimum iniş hızı	0,1 m/s
Max.shifting speed		0,8 m/s-3 km/h
Work cycles ** (with fresh batteries)	Çalışma döngüsü (yeni akülerle)	100-150
Power supply	Güç kaynağı	24V
Battery charger	Akü şarj cihazı	110V - 120V
I Maximum climbing ability	Maksimum tırmanma kabiliyeti	15%